



C09-M-603

3781

BOARD DIPLOMA EXAMINATION, (C-09)

MARCH/APRIL—2016

DME—SIXTH SEMESTER EXAMINATION

INDUSTRIAL ENGINEERING, ESTIMATING AND COSTING

Time : 3 hours]

[*Total Marks* : 80

PART—A

3×10=30

Instructions : (1) Answer **all** questions.
(2) Each question carries **three** marks.
(3) Answers should be brief and straight to the point and shall not exceed *five* simple sentences.

1. What are the therbligs? Give any two symbols.
2. Write three objectives of work measurement.
3. What are the quality characteristics?
4. Draw ideal OC curve.
5. Write three objectives of estimation.
6. What are the elements of cost?
7. Explain the procedure for calculating weight of material for a component.
8. Estimate the machining time to turn a MS rod from 4 cm diameter to 3.5 cm diameter for a length of 15 cm in a single cut. Assume cutting speed 30 m/min and feed 0.4 mm/rev.

9. Briefly explain how to compute power charges in arc welding.
10. How do you estimate foundry cost?

PART—B

10×5=50

Instructions : (1) Answer *any five* questions.
 (2) Each question carries **ten** marks.
 (3) Answers should be comprehensive and the criterion for valuation is the content but not the length of the answer.

11. Briefly explain cycle graph and chrono cycle graph. What is the difference between them? 4+4+2
12. Describe the procedure to be followed for time study by stopwatch method.
13. Explain various types of inspection.
14. (a) Write any five functions of estimation. 5
 (b) Differentiate between estimating and costing. 5
15. The market price of a product is ₹ 200. The discount allowed is 20% of the market price. The selling expenses are equal to factory cost and the relation between material cost, labour cost and factory expenses is 1 : 3 : 2. If the labour cost is ₹ 30, what profit is being made on this product?
16. Estimate the volume of material required for producing 1000 parts as shown in the figure below. Assume that 15% of the finished material is wasted during finishing. All dimensions are in mm. Density of material is 7.8 g/cc.

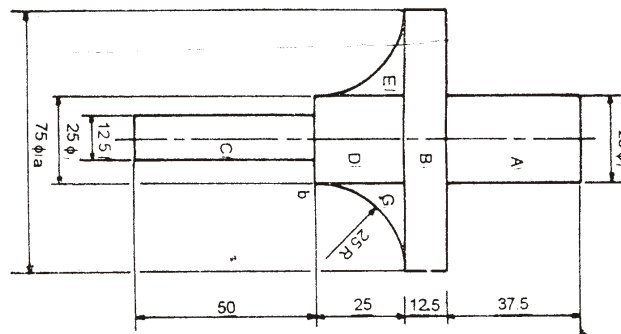

17. Estimate the time required to turn a 50 mm bar to the dimensions as shown in the figure below, with cutting speed 20 m/min and feed 0.7 mm/rev. Assume that all cuts are 2.5 mm deep. Neglect the facing time. All dimensions are in mm :

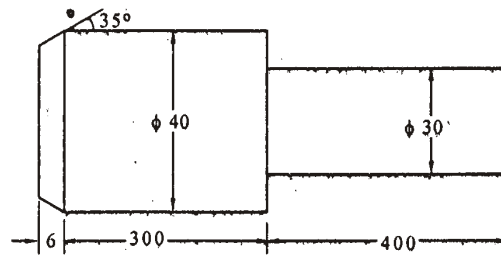

18. A cylindrical boiler drum 3 m \times 1 m dia is to be made from 15 mm thick MS plates. Both the ends are closed by welding circular plates to the drum. Cylindrical portion is welded along the longitudinal seam. Welding is done both on inner and outer sides. Calculate the electric welding cost using the following data :

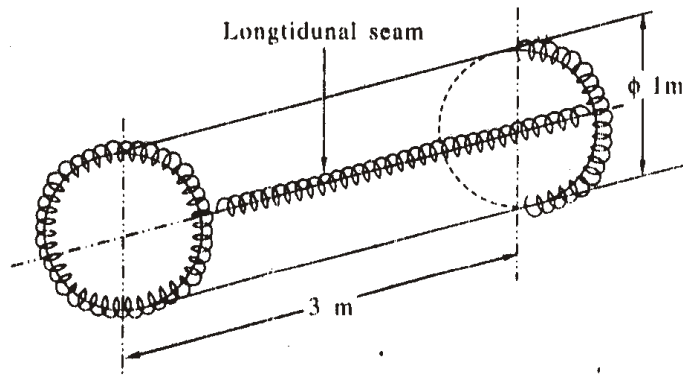

- Rate of welding = 2 m/hr on inner side and 2.5 m/hr on outer side
- Length of electrode required = 1.5 m/min of welding
- Cost of electrodes = ₹6/m
- Power consumption = 4 kWh/m of weld
- Power charges = ₹ 15/kWh
- Labour charges = ₹ 10/hr
- Other overhead charges = 200% of prime cost
